

CHICAGO

Electric[®]Power Tools

12" COMPOUND SLIDE MITER SAW

Model 91852

ASSEMBLY AND OPERATING INSTRUCTIONS

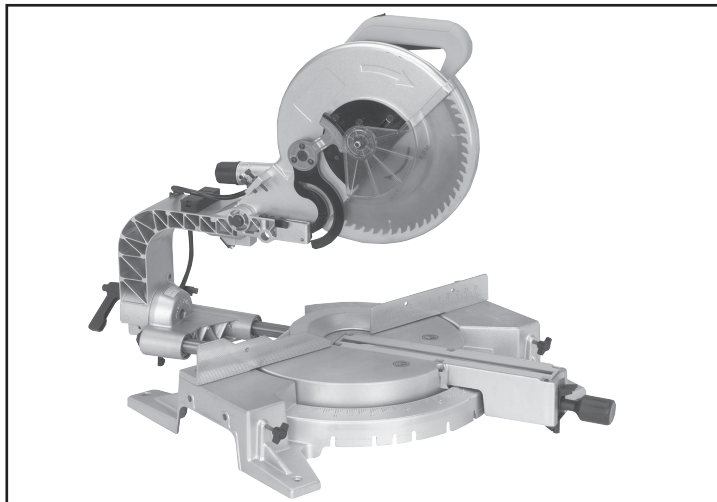

3491 Mission Oaks Blvd., Camarillo, CA 93011

Visit our Web site at: <http://www.harborfreight.com>

**TO PREVENT SERIOUS INJURY,
READ AND UNDERSTAND ALL WARNINGS
AND INSTRUCTIONS BEFORE USE.**

Copyright[©] 2004 by Harbor Freight Tools[®]. All rights reserved. No portion of this manual or any artwork contained herein may be reproduced in any shape or form without the express written consent of Harbor Freight Tools.

For technical questions, please call 1-800-444-3353.

REVISED MANUAL 04/05

PRODUCT SPECIFICATIONS

Item	Description
Electrical Requirements	120 V / 60 Hz / 1800 Input Watts. 15 AMPs / 4100 RPM Motor. Two Prong, Polarized, Power Cord Plug. Power Switch Type: Single Pull Trigger Type. Laser Input Power: Two "AAA" Batteries. Laser Switch Type: Push Button Switch Activation.
Saw Blade (Included) Diameter/Type	12" Diameter. 100-Tooth Carbide Tipped. 5000 RPM Rated Capacity.
Arbor Size	1" Diameter.
Crosscut Capacity	12-3/4" x 4" Vertical @ 90°. 12-3/4" x 1-15/16" Vertical @ 45°.
Blade Tilt Capacity	0° - 45° R & L Miter / 0° - 45° L-Compound.
Positive Stops	0°, 15°, 22.5°, 30°, 45° L – R Miter. 0°, 45° L Bevel.
Turntable Diameter	13-7/8".
Overall Table Size	22-3/4" L x 6-1/2" W.
Overall Dimensions	34-1/2" L x 22-7/8" W x 26-1/4" H.
Weight	43.9 Pounds.



SAVE THIS MANUAL

You will need this manual for the safety warnings and precautions, assembly, operating, inspection, maintenance and cleaning procedures, parts list and assembly diagram. Keep your invoice with this manual. Write the invoice number on the inside of the front cover. Keep this manual and invoice in a safe and dry place for future reference.

GENERAL SAFETY RULES

 **WARNING!**
READ AND UNDERSTAND ALL INSTRUCTIONS
Failure to follow all instructions listed in the following pages may result in electric shock, fire, and/or serious injury.
SAVE THESE INSTRUCTIONS

WORK AREA

1. **Keep your work area clean and well lit.** Cluttered benches and dark areas invite accidents.
2. **Do not operate power tools in explosive atmospheres, such as in the presence of flammable liquids, gases, or dust.** Power tools create sparks which may ignite flammables.

REV 06/05 REV 02/06

3. **Keep bystanders, children, and visitors away while operating a power tool.** Distractions can cause you to lose control. Protect others in the work area from debris such as chips and sparks. Provide barriers or shields as needed.

ELECTRICAL SAFETY

4. **Grounded tools must be plugged into an outlet properly installed and grounded in accordance with all codes and ordinances. Never remove the grounding prong or modify the plug in any way. Do not use any adapter plugs. Check with a qualified electrician if you are in doubt as to whether the outlet is properly grounded.** If the tools should electrically malfunction or break down, grounding provides a low resistance path to carry electricity away from the user.
5. **Double insulated tools are equipped with a polarized plug (one blade is wider than the other). This plug will fit in a polarized outlet only one way. If the plug does not fit fully in the outlet, reverse the plug. If it still does not fit, contact a qualified electrician to install a polarized outlet. Do not change the plug in any way.** Double insulation eliminates the need for the three wire grounded power cord and grounded power supply system.
6. **Avoid body contact with grounded surfaces such as pipes, radiators, ranges, and refrigerators.** There is an increased risk of electric shock if your body is grounded.
7. **Do not expose power tools to rain or wet conditions.** Water entering a power tool will increase the risk of electric shock.
8. **Do not abuse the Power Cord. Never use the Power Cord to carry the tools or pull the Plug from an outlet. Keep the Power Cord away from heat, oil, sharp edges, or moving parts. Replace damaged Power Cords immediately.** Damaged Power Cords increase the risk of electric shock.
9. **When operating a power tool outside, use an outdoor extension cord marked “W-A” or “W”.** These extension cords are rated for outdoor use, and reduce the risk of electric shock.

PERSONAL SAFETY

10. **Stay alert. Watch what you are doing, and use common sense when operating a power tool. Do not use a power tool while tired or under the influence of drugs, alcohol, or medication.** A moment of inattention while operating power tools may result in serious personal injury.
11. **Dress properly. Do not wear loose clothing or jewelry. Contain long hair. Keep your hair, clothing, and gloves away from moving parts.** Loose clothes, jewelry, or long hair can be caught in moving parts.

12. **Avoid accidental starting. Be sure the Power Switch is off before plugging in.** Carrying power tools with your finger on the Power Switch, or plugging in power tools with the Power Switch on, invites accidents.
13. **Remove adjusting keys or wrenches before turning the power tool on.** A wrench or a key that is left attached to a rotating part of the power tool may result in personal injury.
14. **Do not overreach. Keep proper footing and balance at all times.** Proper footing and balance enables better control of the power tool in unexpected situations.
15. **Use safety equipment. Always wear eye protection.** Dust mask, non-skid safety shoes, hard hat or hearing protection must be used for appropriate conditions

TOOL USE AND CARE

16. **Use clamps or other practical ways to secure and support the workpiece to a stable platform.** Holding the work by hand is unstable and may lead to loss of control. Only work on a workpiece that is properly secured.
17. **Do not force the tool. Use the correct tool for your application.** The correct tool will do the job better and safer at the rate for which it is designed.
18. **Do not use the power tool if the Power Switch does not turn it on or off.** Any tool that cannot be controlled with the Power Switch is dangerous and must be replaced.
19. **Disconnect the Power Cord Plug from the power source before making any adjustments, changing accessories, or storing the tool.** Such preventive safety measures reduce the risk of starting the tool accidentally.
20. **Store idle tools out of reach of children and other untrained persons.** Tools are dangerous in the hands of untrained users.
21. **Maintain tools with care. Keep cutting tools sharp and clean.** Properly maintained tools with a sharp cutting edge are less likely to bind and are easier to control. Do not use a damaged tool. Tag damaged tools "Do not use" until repaired.
22. **Check for misalignment or binding of guards and other moving parts, breakage of parts, cracking or breakage of the Saw Blade, and any other condition that may affect the tool's operation. If damaged, have the tool serviced before using.** Many accidents are caused by poorly maintained tools.
23. **Use only accessories that are recommended by the manufacturer for your model.** Accessories that may be suitable for one tool may become hazardous when used on another tool.

SERVICE

24. **Tool service must be performed only by qualified repair personnel.** Service or maintenance performed by unqualified personnel could result in a risk of injury.

25. **When servicing a tool, use only identical replacement parts. Follow instructions in the “*Inspection, Maintenance, And Cleaning*” section of this manual.** Use of unauthorized parts or failure to follow maintenance instructions may create a risk of electric shock or injury.



SPECIFIC SAFETY RULES

1. **Maintain a safe working environment.** Keep the work area well lit. Make sure there is adequate surrounding workspace. Always keep the work area free of obstructions, grease, oil, trash, and other debris. Do not use the Miter Saw in areas near flammable chemicals, dusts, and vapors. Do not use this product in a damp or wet location.
2. **Maintain labels and nameplates on the Miter Saw.** These carry important information. If unreadable or missing, contact Harbor Freight Tools for a replacement.
3. **Do not force the equipment.** This Miter Saw will do the work better and safer at the speed and capacity for which it was designed.
4. **Keep all guards in place and in working order.**
5. **Remove all adjusting wrenches from the Miter Saw before turning it on.**
6. **Do not abuse the Power Cord.** Do not use the Power Cord to pull its Plug from an electrical outlet. Keep the Power Cord away from heat, oil, sharp edges, and moving parts. Route the Power Cord safely. Protect the Power Cord from being damaged by other equipment in the work area. Do not route the Power Cord where it can be walked on or tripped over. Replace a damaged Power Cord immediately.
7. **Do not use this Miter Saw for cutting metals or brittle materials.** Do not cut dangerous materials, such as asbestos which can cause harmful dust or vapors.
8. **To avoid accidental injury, always wear heavy duty work gloves when changing a Saw Blade.**
9. **Before using the Miter Saw, make sure the Saw Blade is properly mounted on the Saw Spindle.** Make sure the Saw Blade is balanced, and is not cracked or bent.
10. **The Saw Blade will become hot while cutting.** Allow the Saw Blade to completely cool before touching.
11. **Make sure the workpiece is free from nails and any other foreign objects which can damage the Saw Blade.**
12. **Keep your body positioned to either side of the Saw Blade, but not in line with the Saw Blade. “Kickback” can cause the Saw to jump backwards.**
13. **Causes and operator prevention of “kickback”:** Kickback is a sudden reaction to a pinched, bound, or misaligned Saw Blade, causing an uncontrolled Saw to lift up and out of the workpiece toward the operator. When the Saw Blade is pinched or bound tightly by the kerf closing down, the Saw Blade stalls and the Motor

reaction drives the tool rapidly toward the operator. If the Saw Blade becomes twisted or misaligned in the cut, the teeth at the back edge of the Saw Blade can dig into the top surface of the workpiece, causing the Saw Blade to climb out of the kerf and jump toward the operator. **Kickback is a result of tool misuse and/or incorrect operating procedures or conditions and can be minimized by taking proper precautions as given below:**

- A. Maintain a firm grip with both hands on the Saw, and position your body and arm to allow you to resist kickback forces.**
 - B. When the Saw Blade is binding, or when interrupting a cut for any reason, release the Power Switch and hold the Saw motionless in the workpiece until the Saw Blade comes to a complete stop.** Never attempt to remove the Saw from the workpiece or pull the Saw backward while the Saw Blade is in motion or kickback can occur.
 - C. When restarting the Saw in the workpiece, center the Saw Blade in the kerf and check that the saw teeth are not engaged into the workpiece.** If the Saw Blade is binding, it may walk up or kickback from the workpiece as the Saw is restarted.
 - D. Support large panels to minimize the risk of Saw Blade pinching and kickback.** Large panels tend to sag under their own weight. Supports must be placed under the panel on both sides, near the line of cut and near the edge of the panel.
 - E. Do not use a dull or damaged Saw Blade.** Unsharpened or improperly set Saw Blades produce a narrow kerf causing excessive friction, Saw Blade binding and kickback.
 - F. Make sure all Saw adjustments are tight and secure before making a cut.** If Saw adjustments shift while cutting, it may cause binding and kickback.
14.  **WARNING! The Lock Pin (128) should always be activated in the “locked down” position when the Saw is not being used and when the Saw is being transported. The Lock Pin should be activated in the “locked up” position when changing Saw Blades. NEVER use the Lock Pin in any cutting operation.** The Lock Pin allows the operator to lock the Saw Blade in position, preventing the Saw Blade from being raised or lowered.
 15. **Allow the Saw Blade to spin up to full speed before feeding it into the workpiece.** Do not force the Saw Blade into the workpiece when cutting. Apply moderate pressure, allowing the Saw Blade to cut without being forced. When turning off the Saw, allow the Saw Blade to spin down and stop on its own. Do not press against the Saw Blade to stop it.
 16. **Turn off the Saw and allow the Saw Blade to stop on its own if the Saw Blade is to be backed out of an uncompleted cut.**
 17. **Industrial applications must follow OSHA requirements.**

18. **The Laser on the Miter Saw is rated as a *Class 2*.** Do not stare directly at the Laser beam. A hazard may exist if you deliberately stare into the beam. **Never aim the Laser beam at any person, animal, or an object other than the workpiece.**
19. **Make sure the Laser beam is aimed at a sturdy workpiece without reflective surfaces.** Reflective surfaces are not suitable for Laser applications, as the reflective surface may direct the Laser beam back at the operator, causing potential eye damage.
20. **Do not attempt to alter the Laser or replace it with a different type.** Doing so may result in hazardous radiation exposure.
21. **Never attempt to remove material stuck in the moving parts of the Miter Saw while the machine is plugged in and running.**
22. **Whenever possible, use clamps or other safe, practical ways to hold and support the workpiece.** Do not attempt to cut material that does not have a flat surface, unless a suitable support is used.
23. **Always keep hands and fingers away from the spinning Saw Blade.**
24. **Use eye, hearing, and breathing protection.** Always wear ANSI-approved safety impact eye goggles, hearing protectors, and dust masks or respirator when working with the Miter Saw.
25. **Do not use this product if under the influence of alcohol or drugs.** Read warning labels on prescriptions to determine if your judgement or reflexes are impaired while taking drugs. If there is any doubt, do not attempt to use this product.
26. **Maintain this product with care.** Keep the Miter Saw clean and dry for better and safer performance. For your safety, service and maintenance should be performed regularly by a qualified technician.
27. **Use the right tool or attachment for the right job.** Do not attempt to force a small tool or attachment to do the work of a larger industrial tool or attachment. There are certain applications for which this product was designed. It will do the job better and more safely at the rate for which it was intended. Do not modify this product, and do not use this product for a purpose for which it was not intended.
28. **Always turn off the Miter Saw and unplug the Power Cord (27) from its electrical outlet before changing accessories or performing inspection, maintenance, or cleaning procedures.**

29.  **WARNING!** People with pacemakers should consult their physician(s) before using this product. Operation of electrical equipment in close proximity to a heart pacemaker could cause interference to or failure of the pacemaker.
30.  **WARNING!** Some dust created by power sanding, sawing, grinding, drilling, and other construction activities, contain chemicals known (to the State of California) to cause cancer, birth defects or other reproductive harm. Some examples of these chemicals are: lead from lead-based paints, crystalline silica from bricks and cement or other masonry products, arsenic and chromium from chemically treated lumber. Your risk from these exposures varies, depending on how often you do this type of work. To reduce your exposure to these chemicals: work in a well ventilated area, and work with approved safety equipment, such as those dust masks that are specially designed to filter out microscopic particles. (*California Health & Safety Code 25249.5, et seq.*)
31.  **WARNING!** The warnings, precautions, and instructions discussed in this manual cannot cover all possible conditions and situations that may occur. The operator must understand that common sense and caution are factors which cannot be built into this product, but must be supplied by the operator.

GROUNDING

WARNING!

Improperly connecting the grounding wire can result in the risk of electric shock. Check with a qualified electrician if you are in doubt as to whether the outlet is properly grounded. Do not modify the power cord plug provided with the tool. Never remove the grounding prong from the plug. Do not use the tool if the power cord or plug is damaged. If damaged, have it repaired by a service facility before use. If the plug will not fit the outlet, have a proper outlet installed by a qualified electrician.

GROUNDED TOOLS: TOOLS WITH THREE PRONG PLUGS

1. Tools marked with “Grounding Required” have a three wire cord and three prong grounding plug. The plug must be connected to a properly grounded outlet. If the tool should electrically malfunction or break down, grounding provides a low resistance path to carry electricity away from the user, reducing the risk of electric shock. **(See Figure A.)**
2. The grounding prong in the plug is connected through the green wire inside the cord to the grounding system in the tool. The green wire in the cord must be the only wire connected to the tool’s grounding system and must never be attached to an electrically “live” terminal. **(See Figure A.)**

3. Your tool must be plugged into an appropriate outlet, properly installed and grounded in accordance with all codes and ordinances. The plug and outlet should look like those in the following illustration. **(See Figure A.)**

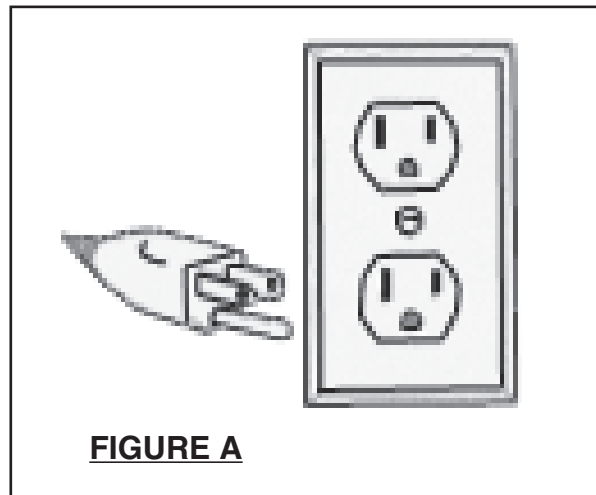

DOUBLE INSULATED TOOLS: TOOLS WITH TWO PRONG PLUGS

4. Tools marked “Double Insulated” do not require grounding. They have a special double insulation system which satisfies OSHA requirements and complies with the applicable standards of Underwriters Laboratories, Inc., the Canadian Standard Association, and the National Electrical Code. **(See Figure B.)**
5. Double insulated tools may be used in either of the 120 volt outlets shown in the following illustration. **(See Figure B.)**

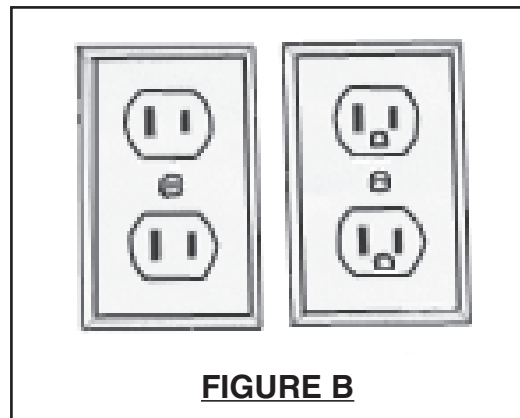

EXTENSION CORDS







1. **Double Insulated** tools can use either a two or three wire extension cord.
2. As the distance from the supply outlet increases, you must use a heavier gauge extension cord. Using extension cords with inadequately sized wire causes a serious drop in voltage, resulting in loss of power and possible tool damage. **(See Figure C)**
3. The smaller the gauge number of the wire, the greater the capacity of the cord. For example, a 14 gauge cord can carry a higher current than a 16 gauge cord. **(See Figure C)**
4. When using more than one extension cord to make up the total length, make sure each cord contains at least the minimum wire size required. **(See Figure C)**
5. If you are using one extension cord for more than one tool, add the nameplate amperes and use the sum to determine the required minimum cord size. **(See Figure C)**
6. If you are using an extension cord outdoors, make sure it is marked with the suffix “W-A” (“W” in Canada) to indicate it is acceptable for outdoor use.
7. Make sure your extension cord is properly wired and in good electrical condition. Always replace a damaged extension cord or have it repaired by a qualified electrician before using it.
8. Protect your extension cords from sharp objects, excessive heat, and damp or wet areas.

RECOMMENDED MINIMUM WIRE GAUGE FOR EXTENSION CORDS* (120 VOLT)					
NAMEPLATE AMPERES (At Full Load)	EXTENSION CORD LENGTH				
	25 FEET	50 FEET	75 FEET	100 FEET	150 FEET
0-2.0	18	18	18	18	16
2.1-3.4	18	18	18	16	14
3.5-5.0	18	18	16	14	12
5.1-7.0	18	16	14	12	12
7.1-12.0	16	14	12	10	-
12.1-16.0	14	12	10	-	-
16.1-20.0	12	10	-	-	-

*Based on limiting the line voltage drop to five volts at 150% of the rated amperes.

FIGURE C

SYMBOLOLOGY

	Double Insulated
	Canadian Standards Association
	Underwriters Laboratories, Inc.
	Volts Alternating Current
	Amperes
	No Load Revolutions Per Minute (RPM)

UNPACKING

When unpacking, check to make sure all the parts shown on the **Parts Lists on pages 23 and 26** are included. If any parts are missing or broken, please call Harbor Freight Tools at the number shown on the cover of this manual as soon as possible.

ASSEMBLY AND OPERATING INSTRUCTIONS

NOTE: For additional references to the parts listed in the following pages, refer to the **Assembly Diagrams on pages 25 and 26.**

To Replace And Install A Saw Blade:

1.  **WARNING!** Prior to performing any assembly and/or adjustment procedures, make sure the Power Cord (27) of the Miter Saw is unplugged from its electrical outlet. Make sure the unit has completely cooled, and wear heavy duty work gloves.
2. When replacing the Saw Blade (4), make sure the new Saw Blade has a **diameter of 12"**, an **RPM rating of at least 5000**, and an **arbor hole of 1" diameter**.
3. When installing a Saw Blade (4), make sure the teeth of the Saw Blade point *downward*, and that the direction of the *arrow* shown on the Saw Blade matches the direction of the *arrow* shown on the Blade Case (54). **(See Figure D.)**

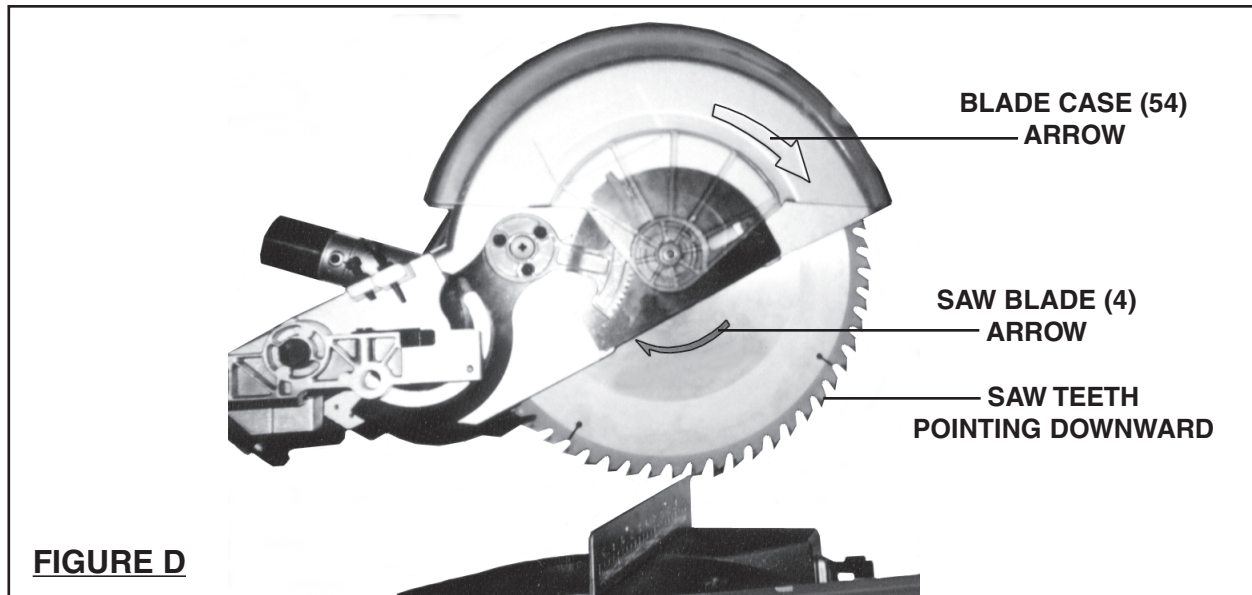

4. **⚠ CAUTION!** The Lock Pin (128) should always be activated in the “locked down” position when the Saw is not being used and when the Saw is being transported. The Lock Pin should be activated in the “locked up” position when changing Saw Blades. **NEVER** use the Lock Pin in any cutting operation. The Lock Pin allows the operator to lock the Saw Blade in position, preventing the Saw Blade from being raised or lowered. (See Figure E, next page.)
5. Lock the Saw Blade (4) in its *upward* position. To do so, pull out on the Knob (124). Raise and hold the body of the Miter Saw fully upward. Turn the Knob 90 degrees. Then, insert the Knob into the *deep* slot in its locked position. (See Figure E.)
6. *Loosen* the Screw (57) that holds the Center Cover (56) in place. Then, *remove* the Screw (62). (See Figure F, next page.)
7. Rotate the Center Cover (56) up and out of the way. (See Figure G, next page.)

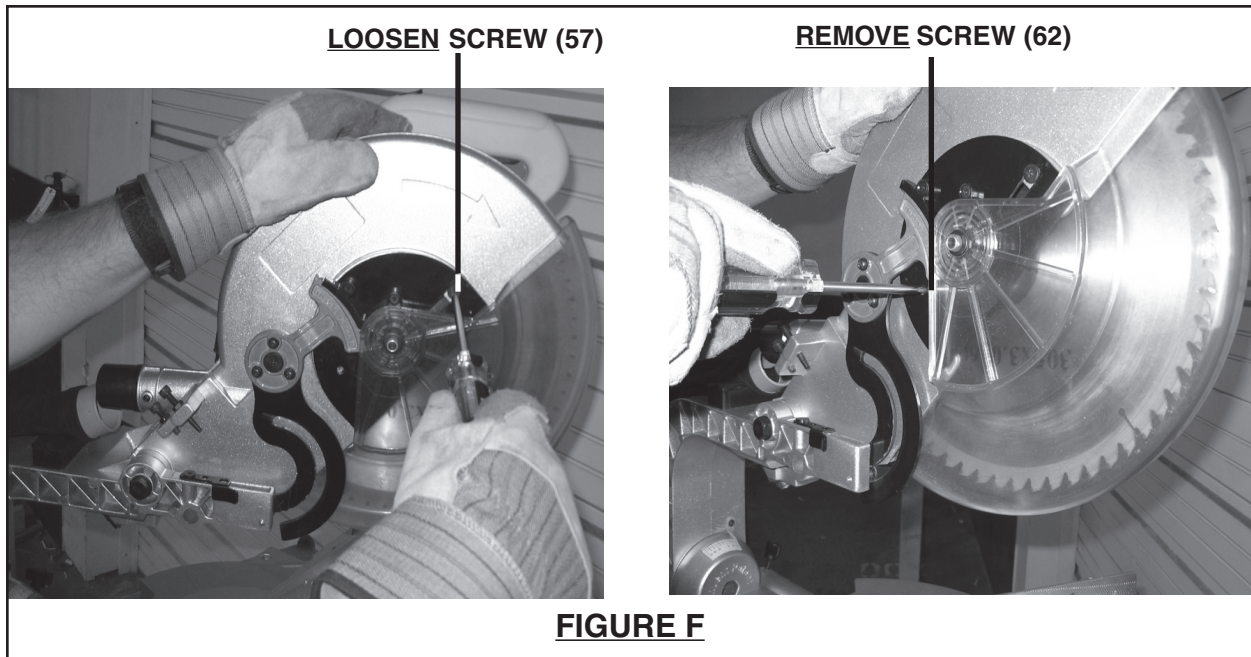
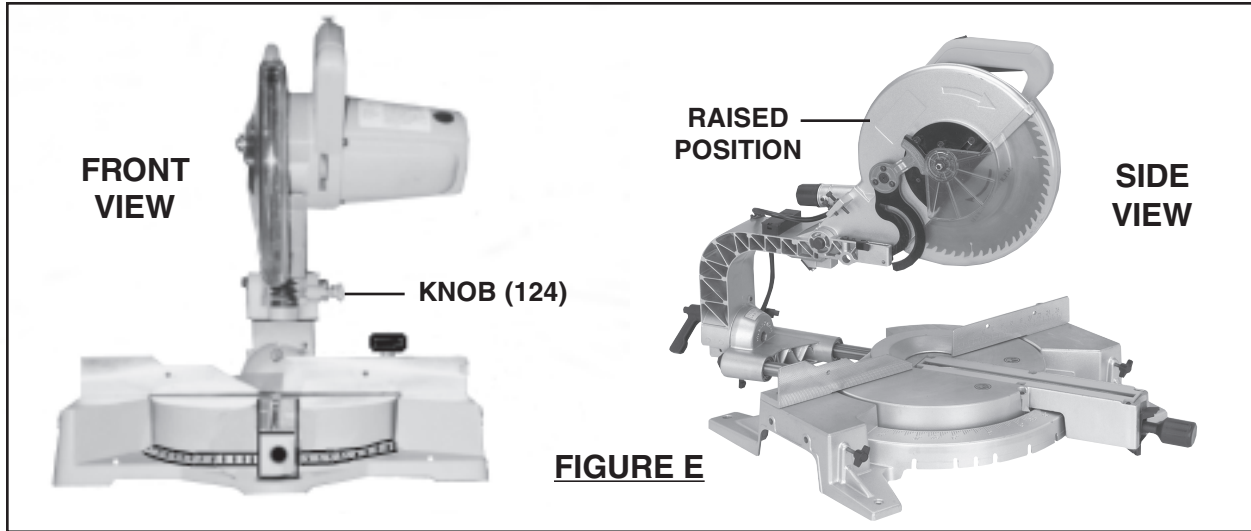

8. Depress the Spindle Lock (77) to keep the Saw Blade (4) from turning.
(See Figure H.)

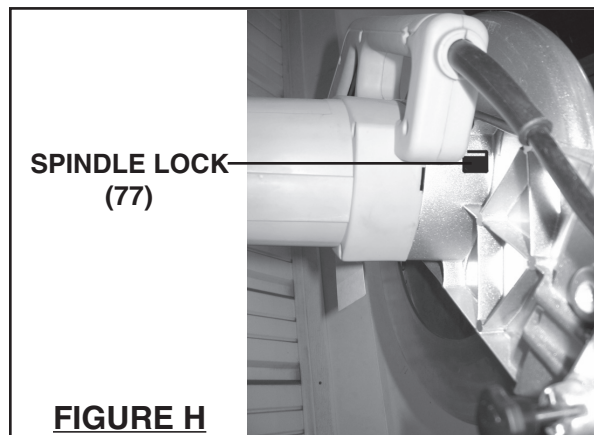
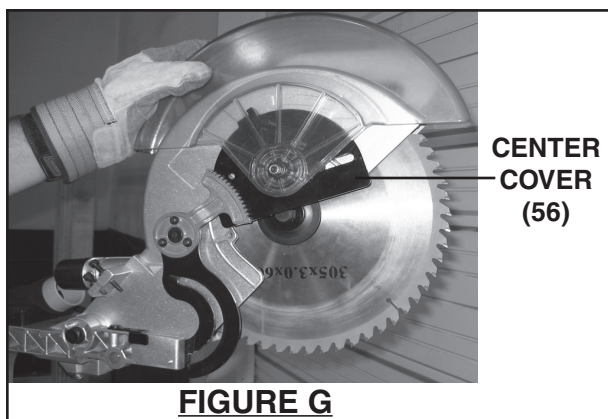

9. Unscrew and remove the Hex Head Bolt (1). Then, remove the Spindle Washer (2) and Flange (3). **(See Figure I.)**

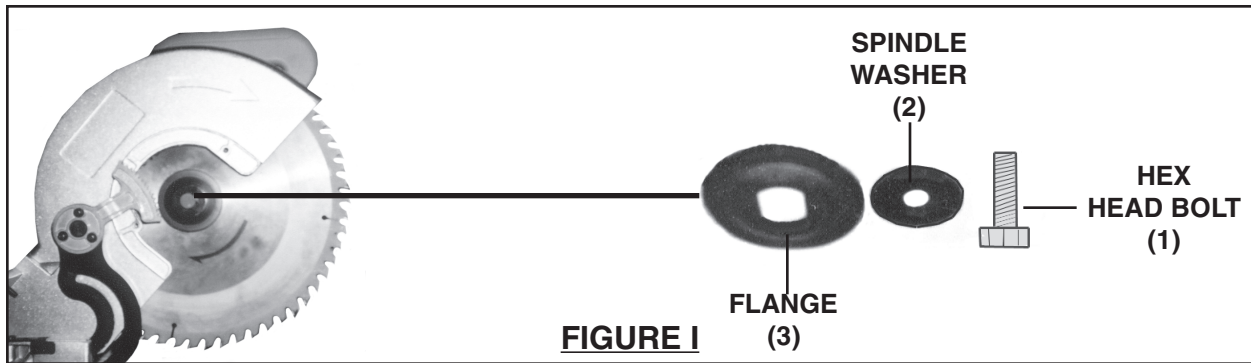

10. Release pressure on the Safety Lock Grip (42). **(See Figure H.)**
11. *Wearing heavy duty work gloves to avoid accidental cuts,* remove the old Saw Blade (4). **(See Figure J.)**

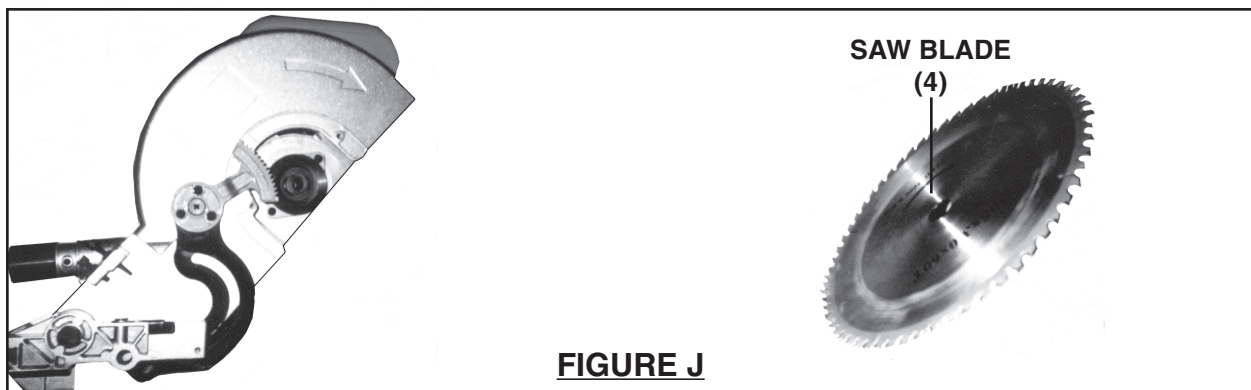

12. Install the new Saw Blade (4), making sure the teeth of the Saw Blade are pointing *downward*. **(See Figure D.)**
13. Reassemble the Flange (3), Spindle Washer (2), and Hex Head Bolt (1) *firmly*. **(See Figure I.)**
14. Swing the Center Cover (56) back in place, making sure the Blade Guard (72) covers the Saw Blade (4). **(See Figure G.)**
15. Reinstall the Screw (62), and retighten the Screw (57). **(See Figure F.)**
16. Make sure the Blade Guard (72) returns to its original position prior to operating the Miter Saw.
17. **⚠ CAUTION!** Make sure to pull out on the Knob (124). Turn the Knob 90 degrees. Then, insert the Knob into the *shallow* slot in its unlocked position. **NEVER** use the Knob in any cutting operation.

To Assemble/Adjust Additional Accessories:

1. A workpiece Clamp Assembly (96, 99, 101, 109, 111) can be installed by inserting the Assembly into the hole located in the Guide Fence (97). Once inserted, lock the Assembly in place with a Wing Screw (103). To clamp the workpiece to the Work Table (87) of the Miter Saw, turn the Adjusting Knob (111) clockwise. **(See Figure K.)**
2. A workpiece Holder (105) can be inserted into each side of the Base (100), adjusted for the desired length, and locked in place with a Wing Screw (103). The Holders should be used as supports when cutting longer length workpieces. **(See Figure K.)**
3. The Baffle Plate (104) can be attached to the workpiece Holder (105) and locked in place with a Wing Screw (103). Once attached and locked in place, the Baffle Plate allows you to make repeated cuts of the same length. To do so, loosen the Wing Screw (103) that holds the Holder (105) in place. Measure the distance from the Saw Blade (4) to the Baffle Plate and, when the desired length of cut is determined, lock the Holder in place with the Wing Screw. **(See Figure K.)**
4. **Guide Fence Adjustment:** Loosen all four Bolts (108) on the back side of the Guide Fence (97). Using a square (not included), make sure that the fence is at a perfect right angle to the blade when the blade is set at 0° angle. Also, ensure that the blade does not contact the fence in any of the blade's positions. Tighten the Bolts (108) to lock the Guide Fence in position.

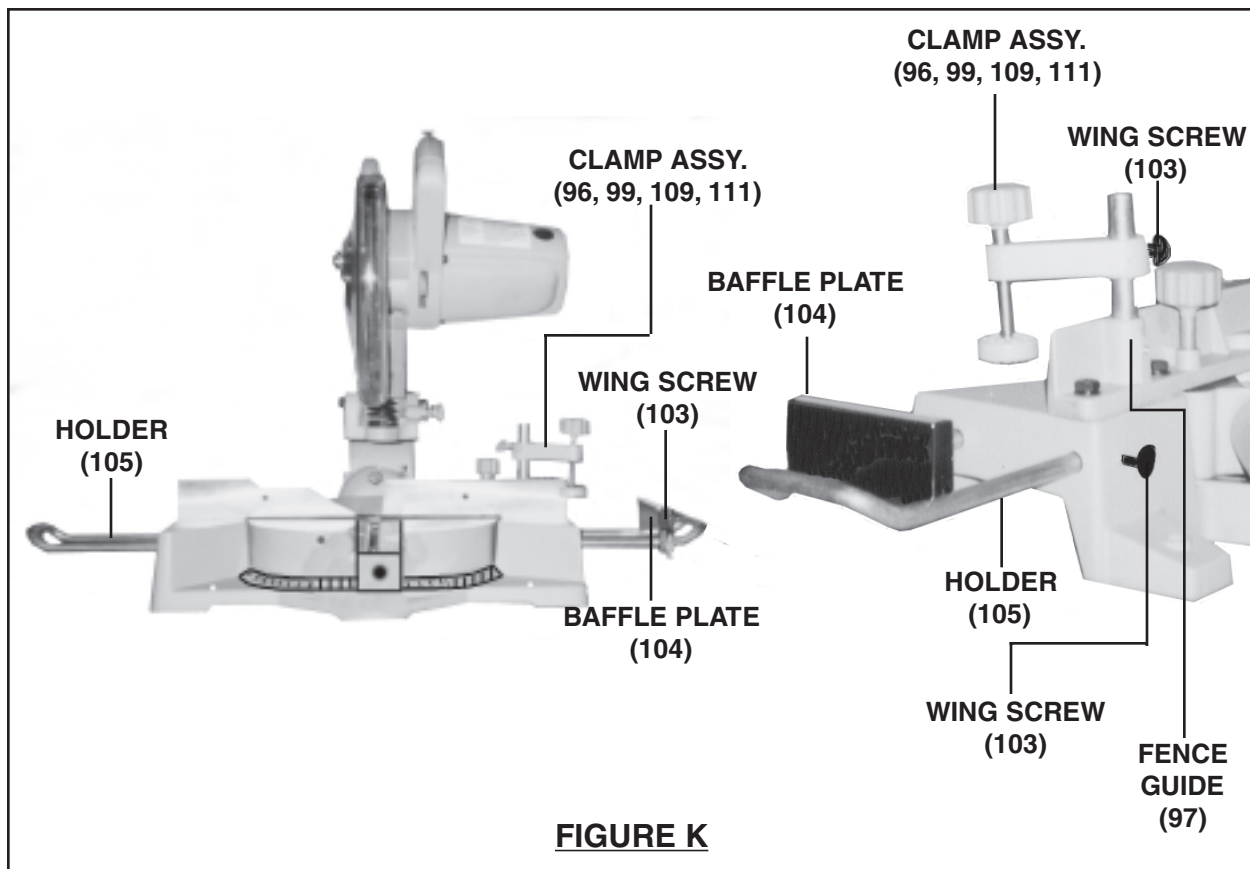

The Safety Cover:

1. The transparent Safety Cover (72) automatically rotates to cover the Saw Blade (4) when the Blade Case (54) is lifted. When the Blade Case is lowered, the Safety Cover rotates back out of the way. **(See Figure L.)**
2. **Do not disconnect or remove the Safety Cover (72). Do not operate the Miter Saw if the Safety Cover is damaged or missing. (See Figure L.)**
3. If the transparent Safety Cover (72) becomes so dirty that the Saw Blade (4) cannot be seen clearly, disconnect the electrical Power Cord from its electrical outlet and clean the Safety Cover with a soft, damp, cloth. A mild detergent may be used, but do not use solvents which may damage the Safety Cover. **(See Figure L.)**

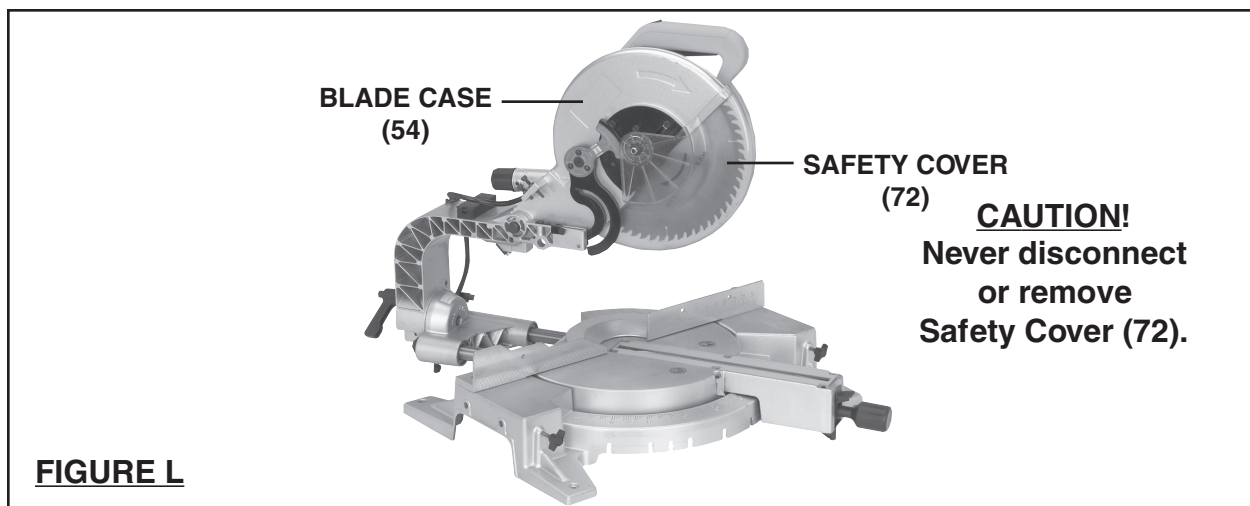

The Safety Button And Switch Lever:

1. Before plugging in the Miter Saw, check the operation of the Safety Button (37) and the Switch Lever (41). Do not operate the Miter Saw if either the Safety Button or Switch Lever are not operating properly. **(See Figure M, next page.)**
2. Depress the Safety Button (37) with your thumb, and squeeze the Switch Lever (41) which will start the Miter Saw. Then, release the Safety Button. **(See Figure M.)**
3. To turn off the Miter Saw, release the Switch Lever (41). This allows the Safety Button (37) to return to the "OFF" position. **(See Figure M.)**
4. Do not force the Switch Lever (41) if the Safety Button (37) is not working properly. This will damage the Switch Lever mechanism. **(See Figure M.)**

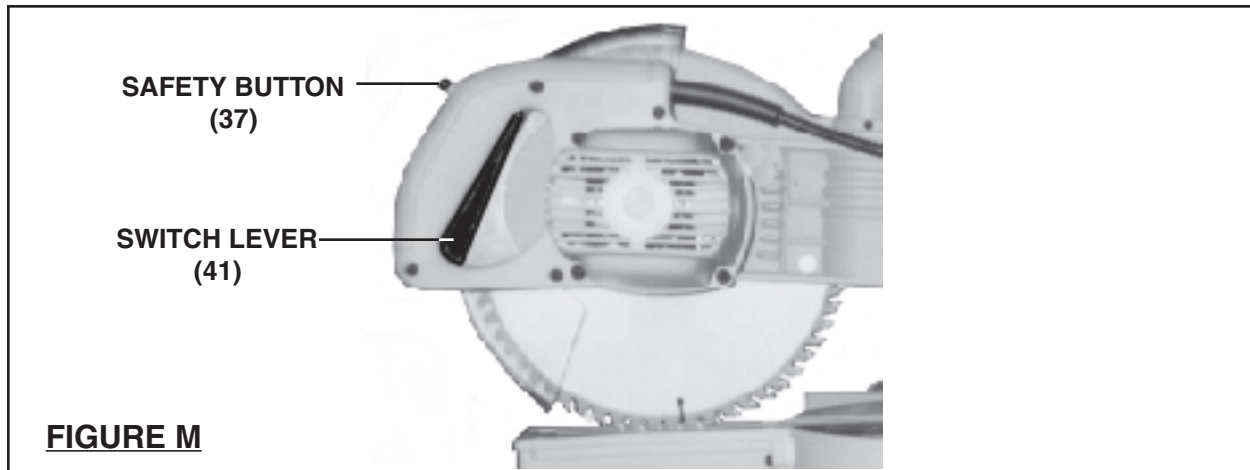

The Laser Assembly:

1. The Miter Saw is equipped with a Laser Assembly (148) for improved cutting accuracy and convenience. **(See Figure N.)**
2. The Laser Assembly (148) is powered by two “AAA” Batteries (included). To install the Batteries, open the Battery Box Cap (137). Insert two AAA Batteries into the Battery Box (143), making sure to match the polarity of the Batteries with the polarity signs (+ and -) as shown in the Battery Box. **(See Figure N.)**
3. To activate the Laser Assembly (148) depress the Laser Switch (136). Align the cut line on the woodstock with the Laser Beam. Then, turn on the Miter Saw and make the cut. **NOTE:** Turn on the Laser *only* before you are ready to start cutting, and make sure the Laser Assembly is off when not cutting. **(See Figure N.)**

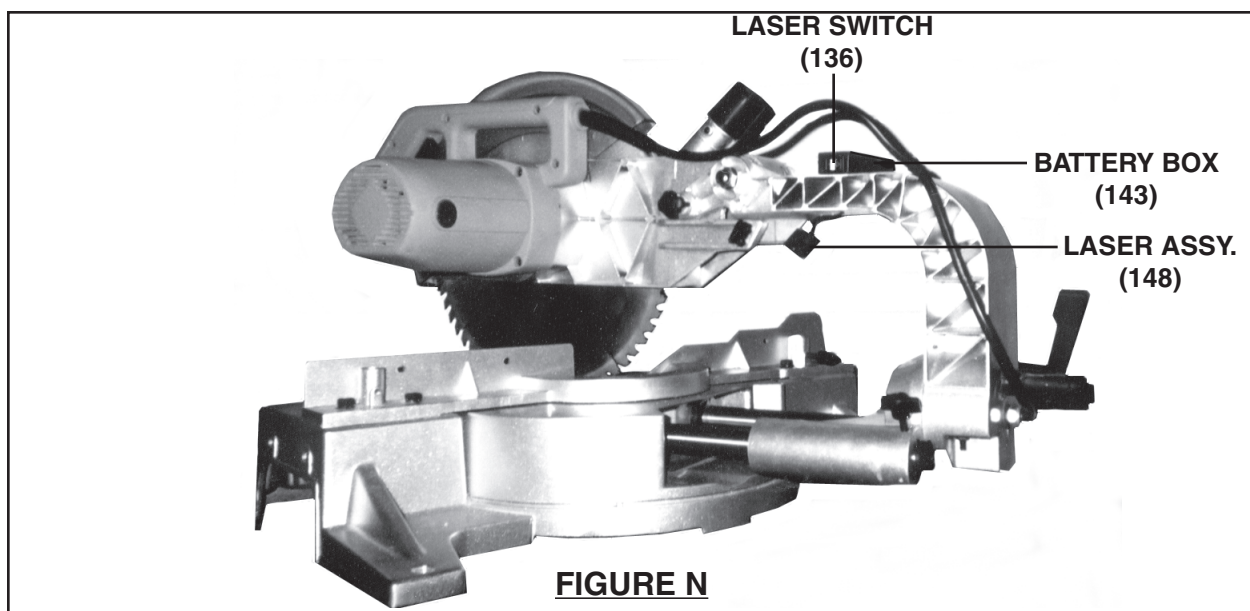

The Elbow Dust Chute:

1. The Elbow Dust Chute (66) exhausts the wood chips and saw dust when the Miter Saw is in operation. **(See Figure O.)**
2. The *outside* diameter of the Elbow Dust Chute is 1-3/8". Attach Dust Collection Bag (158) to the Elbow Dust Chute or attach vacuum hose (not included). It is recommended that *only* a qualified technician attach a vacuum hose. **(See Figure O.)**

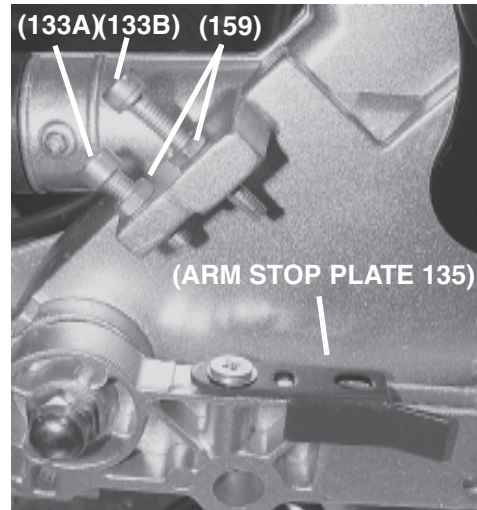
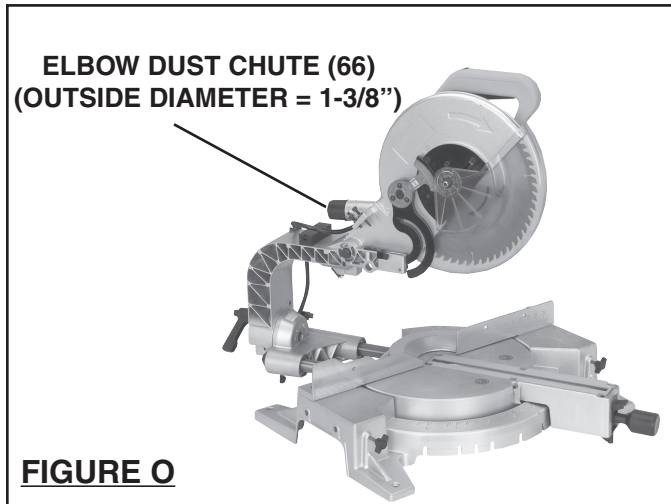

Depth Adjustment Parts Closeup Photo

Adjust The Cutting Depth:

1.  **WARNING!** Prior to performing this procedure, make sure the Power Cord (27) of the Miter Saw is unplugged from its electrical outlet.
2. The depth of cut may be adjusted to a maximum of 4" at 90°, and 1-15/16" at 45°.
3. Loosen the Wing Screw (103) and pull the Miter Saw's Motor Housing (31) forward as far as it will go. Notice whether the edge of the Saw Blade (4) passes completely through the Kerf Board (151). **(See Figure P, next page)**
4. If the Saw Blade (4) does not pass completely through the Kerf Board (151), lower the Saw Blade slightly by turning the two Bolts (133A,133B) *counterclockwise*. **(See Figure P)**
5. The rear Short Bolt (133A) should be adjusted for maximum allowable depth of cut. The forward Long Bolt (133B) is used in conjunction with the Arm Stop Plate (135). The Long Bolt (133B) can be adjusted for a secondary, less deep cut, if desired. Pivot the Arm Stop Plate (135) outward to use the front stop, or push the Arm Stop Plate (135) inward, and the Long Bolt (133B) will bypass it, allowing full depth of cut. After making the adjustments to the two Bolts (133A, 133B), tighten the two Jam nuts (159) to keep the two Bolts (133A, 133B) from moving. **(See Photo Above)**
6. After adjusting the two Bolts (133A,133B), press down on the Miter Saw and make sure the Saw Blade (4) does not contact the bottom of the Work Table (87) or any other part of the Saw Base. **(See Figure P)**

6. If the Saw Blade (4) touches the Work Table (87) or any other part of the Saw Base, turn the two Bolts (133A, 133B) *clockwise* to raise the Saw Blade slightly until it clears. (See Figure P.)

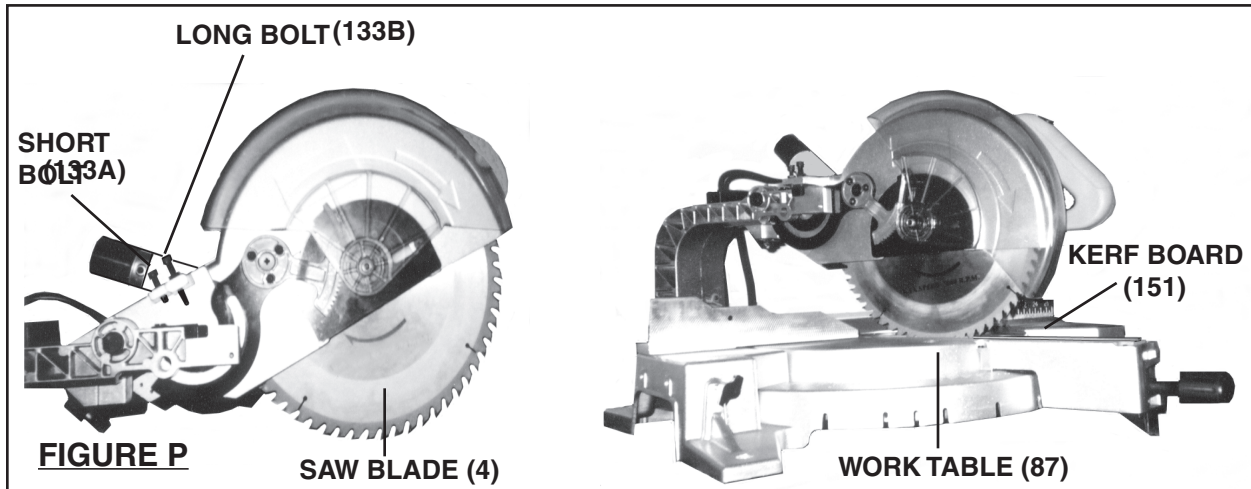

To Adjust The Miter Angle:

1.  **WARNING!** Prior to performing this procedure, make sure the Power Cord of the Miter Saw is unplugged from its electrical outlet.
2. The miter angle of a cut may be adjusted 0 - 45 degrees to the right or left. To do so, loosen the Fasten Knob (153) located at the front of the Work Table (87). (See Figure Q.)
3. Move the Work Table (87) to the right or left until the desired miter angle of cut is indicated by the Miter Scale located on the Base (100). Then, retighten the Fasten Knob (153) to lock the Miter Saw in place. (See Figure Q.)

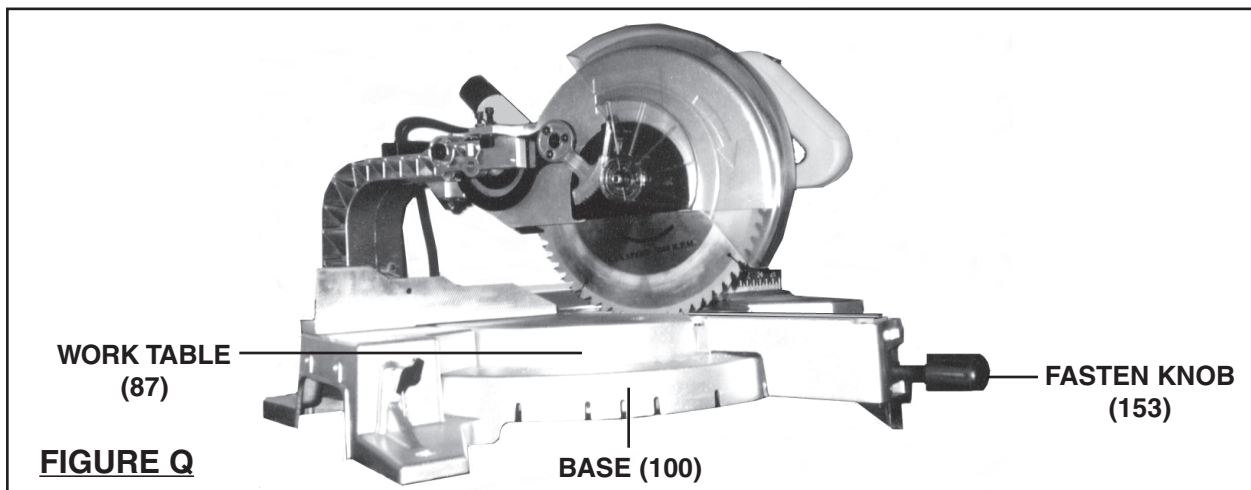

REV 12/05

To Adjust The Angle Of Cut:

1.  **WARNING!** Prior to performing this procedure, make sure the Power Cord of the Miter Saw is unplugged from its electrical outlet.
2. The bevel angle (or Saw Blade *tilt* capacity) may be adjusted from 0 - 45° degrees to the left. To do so, loosen the Lock Lever (122) located at the rear of the Miter Saw. (See Figure R.)
3. Tilt the Arm Holder (132) until the desired bevel angle of cut is achieved as indicated on the Scale Plate (155). Then, retighten the Lock Lever (122) to lock the Arm Holder in place. (See Figure R.)

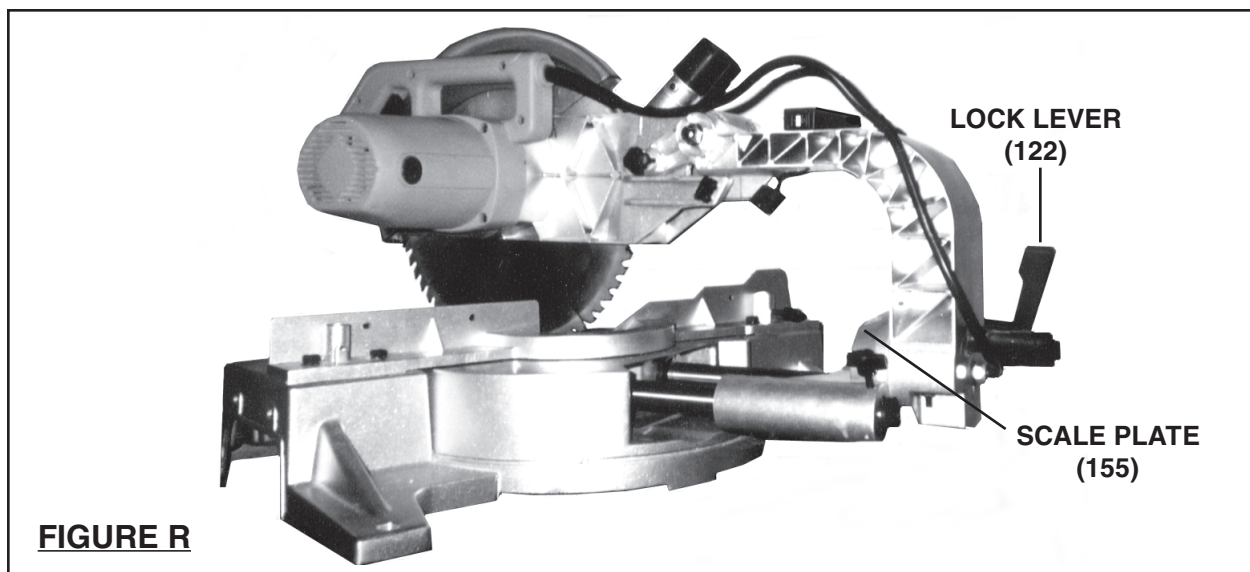

Basic Operation:

1. **Make sure the Power Cord (27) of the Miter Saw is unplugged from its electrical outlet.** Then, if necessary, make adjustments to the workpiece Holder (105), Baffle Plate (104), cutting depth, and miter angle and/or bevel angle.
2. Raise the Motor Housing (31) to its full “UP” position.
3. Check to make sure the Safety Button (37) and the Switch Lever (41) are operating properly.
4. Place the workpiece on the Work Table (87) and against the Guide Fence (97).
5. Use the Clamp Assembly (96, 99, 109, 111) to hold the workpiece in place.

6. **Plug the Power Cord into the nearest 120 volt, grounded, electrical outlet.**
7. Depress the Safety Button (37) with your thumb, and squeeze the Switch Lever (41). Then, release the Safety Button.
8. When the Saw Blade (4) is turning at full speed, slowly bring down the Motor Housing (31) to complete the cut. **NOTE:** Feed the Saw Blade into the workpiece **gradually**. Do not force the machine to remove material faster than it was designed to cut.
9. When cutting a large workpiece, make sure its entire length is properly supported. If necessary, use a roller stand (not included) with a larger workpiece.
10. Never attempt to remove material stuck in the moving parts of the Miter Saw while it is plugged in and running.
11. Turn off the Miter Saw if the workpiece is to be backed out of an uncompleted cut.
12. When the cut is complete, release the Switch Lever (41). This allows the Safety Button (37) to return to the “OFF” position.
13. Wait until the Saw Blade (4) comes to a complete stop. Then, raise the Motor Housing (31) to its full “UP” position.
14. Loosen the Clamp Assembly (96, 99, 109, 111), and remove the workpiece and scrap material from the Work Table (87).
15. **Unplug the Power Cord (27) from its electrical outlet.**

INSPECTION, MAINTENANCE, AND CLEANING

1.  **WARNING!** Always make sure the Switch Lever (41) is in its “OFF” position, and unplug the Power Cord (27) from its 120 volt electrical outlet before performing any inspection, adjustments, maintenance, or cleaning.
2. **Before each use**, inspect the general condition of the Miter Saw. Check for loose screws, misalignment or binding of moving parts, cracked or broken parts, damaged electrical wiring, loose, cracked, or bent Saw Blade (4), and any other condition that may affect its safe operation. If abnormal noise or vibration occurs, have the problem corrected before further use.
Do not use damaged equipment.

3. **Daily:** With a soft brush, cloth, or vacuum, remove all dust and debris from the Miter Saw. Then, use a premium quality, lightweight machine oil to lubricate all moving parts except the Saw Blade (4).
4. **To replace the Motor Carbon Brushes:** It may become necessary at some-time to replace the *two* Carbon Brushes (26) when the Motor performance decreases, or stops working completely. **The Carbon Brushes are located on each side of the Motor Housing (31).** To do so, remove the two Brush Holder Caps (23). Then, remove the two Carbon Brushes from the Brush Holders (25). If the Carbon Brushes are worn down more than 1/2, replace *both* Carbon Brushes. If, however, the Carbon Brushes are just dirty they may be cleaned by rubbing them with a pencil eraser. When installing the Carbon Brushes, make sure the carbon portion of the Carbon Brushes contact the Motor Armature, and that the springs face away from the Motor. Also, make sure the springs operate freely. After cleaning or replacement, replace the Brush Holders.
NOTE: New Carbon Brushes tend to arc or spark when first used *until* they wear and conform to the Motor's Armature. (See Assy. Diagram.)
5. **NOTE: With the exceptions of Steps #1, #2, #3, and #4 all other maintenance and servicing should be performed *only* by a qualified service technician.**

PLEASE READ THE FOLLOWING CAREFULLY
--

THE MANUFACTURER AND/OR DISTRIBUTOR HAS PROVIDED THE PARTS LIST AND ASSEMBLY DIAGRAM IN THIS MANUAL AS A REFERENCE TOOL ONLY. NEITHER THE MANUFACTURER OR DISTRIBUTOR MAKES ANY REPRESENTATION OR WARRANTY OF ANY KIND TO THE BUYER THAT HE OR SHE IS QUALIFIED TO MAKE ANY REPAIRS TO THE PRODUCT, OR THAT HE OR SHE IS QUALIFIED TO REPLACE ANY PARTS OF THE PRODUCT. IN FACT, THE MANUFACTURER AND/OR DISTRIBUTOR EXPRESSLY STATES THAT ALL REPAIRS AND PARTS REPLACEMENTS SHOULD BE UNDERTAKEN BY CERTIFIED AND LICENSED TECHNICIANS, AND NOT BY THE BUYER. THE BUYER ASSUMES ALL RISK AND LIABILITY ARISING OUT OF HIS OR HER REPAIRS TO THE ORIGINAL PRODUCT OR REPLACEMENT PARTS THERETO, OR ARISING OUT OF HIS OR HER INSTALLATION OF REPLACEMENT PARTS THERETO.

PARTS LIST

Part #	Description	Q ty	Part #	Description	Q ty
1	Hex Head Bolt	1	45	Spring Washer	7
2	Spindle Washer	1	46	Flat Washer	7
3	Flange	1	47	Pan Head Screw	1
4	Saw Blade	1	48	Spring Cover	1
5	Ball Bearing	1	49	Safety Lock Shaft	1
6	Flange	1	50	Torsion Spring	1
7	Fan	1	51	Hex Head Bolt	1
8	Pan Head Screw	2	52	Clip	1
9	Spring Washer	2	53	Hex Head Bolt	1
10	Flat Washer	18	54	Blade Case Complete	1
11	Bearing Cover	1	55	Nut	4
12	Fan Guide	1	56	Center Cover	1
13	Bearing	1	57	Screw	1
14	Bearing Box	1	58	Gear Link Plate	1
15	Gear	1	59	Gear Plate	1
16	Armature Assembly	1	60	Link Plate	1
17	Pan Head Screw	2	61	Flat Head Screw	3
18	Spindle	1	62	Pan Head Screw	3
19	Key	1	63	Screw	2
20	Retaining Ring	1	64	Bush	2
21	Bush	1	65	Pan Head Screw	1
22	Stator Assembly	1	66	Elbow Dust Chute	1
23	Brush Holder Cap	2	67	Compressor Spring	1
24	Ball Bearing	1	68	Plastic Stop	1
25	Brush Holder	2	69	Nut	1
26	Carbon Brush	2	70	Spring Washer	1
27	Power Cord	1	71	Washer	1
28	Cord Guard	1	72	Blade Guard	1
29	Pan Head Screw	4	73	Stopper Plate	1
30	Pan Head Screw	6	74	Rivet	1
31	Motor Housing	1	75	Spring	1
32	Cord Clips	1	76	Safety Cover Gear	1
33	Screw	2	77	Spindle Lock	1
34	Inductance	2	78	Shaft Lock Grip	1
35	Capacitor	1	79	Fastener	1
36	Safety Lever	1	80	Pin	1
37	Safety Button	1	81	Compressor Spring	1
38	Switch	1	82	Fasten Lever	
39	Compressor Spring	1	83	Front Cover	1
40	Screw	1	84	Pan Head Screw	4
41	Switch Lever	1	85	Screw	2
42	Safety Lock Grip	1	86	Reinforced Nut	1
43	Safety Lock	1	87	Work Table	1
44	Pan Head Screw	7	88	Rubber Washer	2

NOTE: Some parts are listed and shown for illustration purposes only, and are not available individually as replacement parts.

PARTS LIST - CONTINUED

Part #	Description	Q ty	Part #	Description	Q ty
89	Retaining Ring	2	133a	Short Bolt	1
90	Dustproof Cover	4	133b	Long Bolt	1
91	Felt Ring	4	135	Arm Stop Plate	1
92	Linear Ball Bearing	3	136	Laser Switch	1
93	Slide Bar	1	137	Battery Box Cap	1
94	Longer Slider Bar	1	138	Battery AAA Size	2
95	Lock Ring	1	139	Battery Terminal 1	1
96	Wing Screw	2	140	Battery Terminal 2	1
97	Guide Fence	1	141	Battery Terminal 3	1
98	Slide Plate	3	142	Screw	2
99	Clamp Shaft	1	143	Battery Box	1
100	Base Complete	1	144	Hex Head Bolt	1
101	Vise Plate	1	145	Torsion Spring	1
102	Rubber Foot	5	146	Sleeve	1
103	Wing Screw	5	147	Screw	2
104	Baffle Plate	1	148	Laser Assembly	1
105	Holder	2	149	Pan Head Screw	7
106	Flat Washer	4	150	Hex Socket Head Bolt	1
107	Spring Washer	4	151	Kerf Board	1
108	Hex Head Bolt	4	152	Index	1
109	Clamp Assembly	1	153	Fasten Knob	1
110	Hex Bolt	4	154	Index	1
111	Adjusting Knob	1	155	Scale Plate	1
112	Support Foot	1	156	Arm Complete	1
113	Insert	2	157	Hex Head Bolt	1
114	Lock Ring	2	158	Dust Collection Bag	1
115	Rubber Ring	2	159	Jam Nut	2
116	Slide Bar Support	1			
117	Hex Socket Head Bolt	2			
118	Flat Washer	5			
119	Spring Washer	2			
120	Shaft	1			
121	Spring	1			
122	Lock Lever	1			
123	Shaft Lock Assembly	1			
124	Knob	1			
125	Nut	2			
126	Compressor Spring	1			
127	Flat Washer	1			
128	Lock Pin	1			
129	Pin	1			
130	Lock Nut	1			
131	Center Spindle	1			
132	Arm Holder Complete	1			

NOTE: Some parts are listed and shown for illustration purposes only, and are not available individually as replacement parts.

REV 07/05; 12/05

ASSEMBLY DIAGRAM

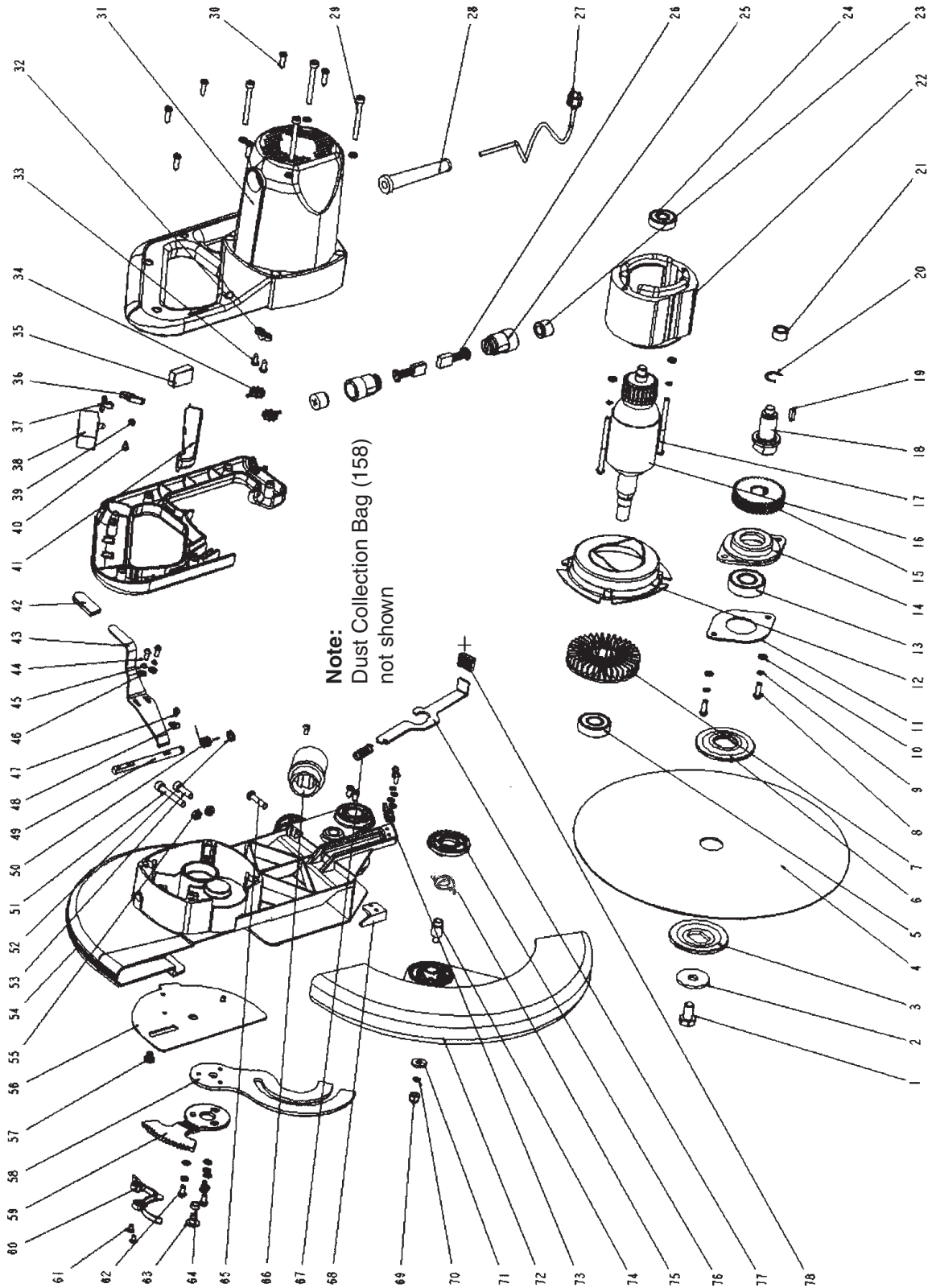

NOTE: Some parts are listed and shown for illustration purposes only, and are not available individually as replacement parts.

REV 07/05; 12/05

ASSEMBLY DIAGRAM- CONTINUED

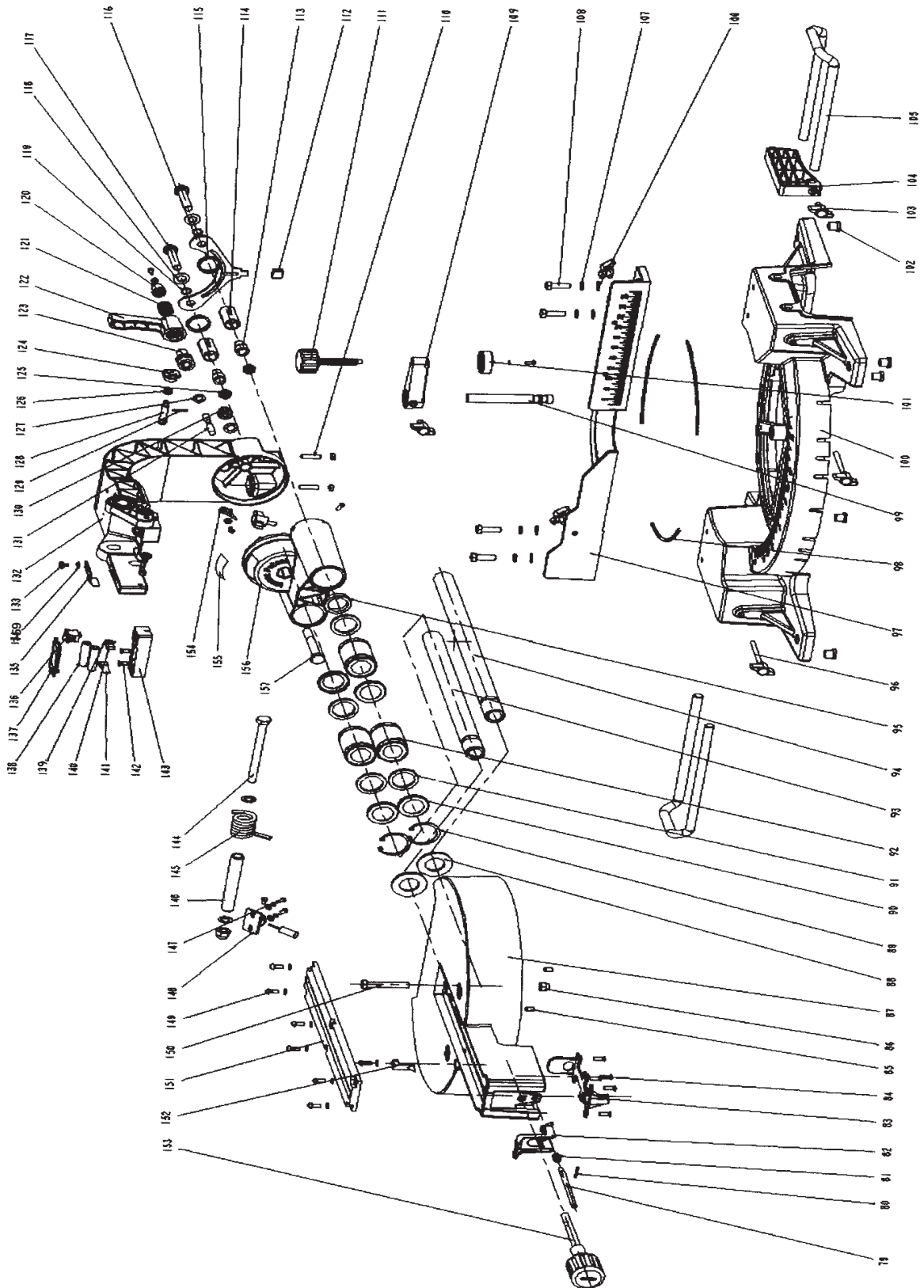

NOTE: Part # 143, Battery Box, is located on the bottom of the Arm Holder Complete (Part# 156).

REV 03/06